

PRODUCT NUMBER: 811-22-002-30-001101

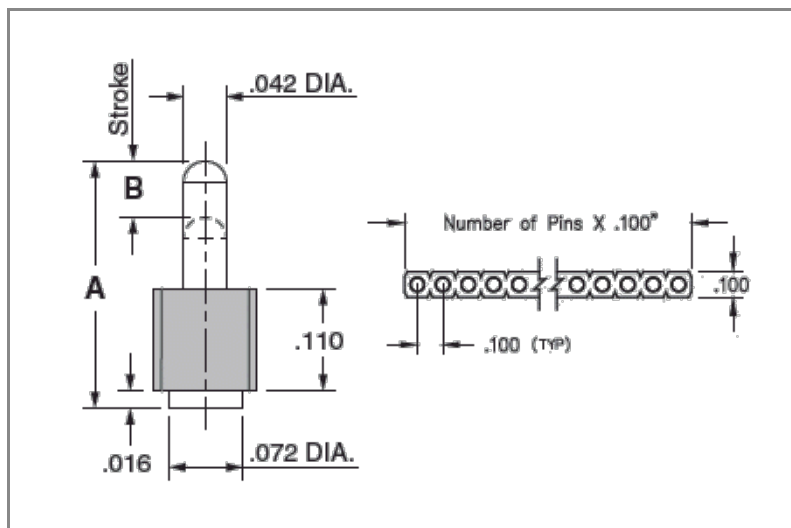

DESCRIPTION

Spring-Loaded Pogo Pin Header Strip
 PCB Mount Spring-Loaded Header
 Vertical Surface Mount

Rows: Single Row (1)

Pitch: .100" (2,540mm)

Stroke: .045" (1,143mm)

Clip Grid: 30

Pin Window Pattern 001

Plating Code: 22

Shell: 20µ" Gold over 100µ" Nickel

Inner Contact: 10µ" Gold

Insulator Pin Clip Type: 101

Initial Height: .177" (4,496mm)

Mounting Type: Surface Mount

Insulator Information:

Nylon 46 High Temperature

# Pins	ROHS Compliant	A Dim	B Dim
2		.177" (4,496mm)	.045" (1,143mm)

LOOSE PIN/RECEPTACLE USED:

0900 (Brass Alloy)

BRASS ALLOY 360 per ASTM B 16, or 385 per ASTM B455

Properties of BRASS ALLOY 360 ASTM B 16:

- Chemical composition: Cu 63% (max), Pb 3.7% (max)†, Fe .35% (max), Zn remainder
- Temper as machined: H02/H04
- Yield Strength: 25-45 ksi
- Tensile strength: 57-80 ksi
- Hardness as machined: 80-90 Rockwell B
- Electrical conductivity: 26% IACS*
- Melting point: 1000 °C/840 °C (liquidus/solidus)

Properties of BRASS ALLOY 385 ASTM B 455:

- Chemical composition: Cu 60% (max), Pb 3.5% (max)†, Fe .35% (max), Zn remainder
- Temper as machined: H02/H04
- Yield Strength: 16 ksi(min)
- Tensile strength: 48 ksi(min)
- Hardness as machined: 80-90 Rockwell B

- Electrical conductivity: 28% IACS*
- Melting point: 1000°C/840°C (liquidus/solidus)

After machining, brass parts are often annealed (softened) for subsequent bending, swaging or crimping. A partial anneal down to 60±10 RB is recommended for 90° bends, a full anneal down to 35±15 RB is recommended for pins or terminals that are swaged (riveted) to a circuit board or crimped to a wire.

Note: Plated Brass parts need a barrier plate to prevent zinc diffusion, 50µ" min. nickel or 100µ" min. copper is recommended by ASTM B 545 and 579. ASTM B 488 also recommends a 50µ" min. nickel barrier plate beneath gold to prevent copper diffusion inherent with all copper alloy products.

†RoHS-2 directive 2011/65/EU, exemption 6c allows up to 4% lead as an alloy agent in copper.

*International Annealed Copper Standard, i.e. as a % of pure copper.

INSULATOR MATERIAL:

Nylon 46 (Injection Molded)

Properties:

- High Temp. {30% glass filled} or {45% glass filled}, (black). Flammability rating UL 94 V-0
- Material Heat Deflection Temp. (per ASTM D 648): 554°F (290°C) @ 264 psi

Note: Materials with HDT above 446°F (230°C) are considered suitable for "eutectic" reflow soldering. For "lead-free" reflow soldering, choose materials with an HDT above 500°F (260°C).

ADDITIONAL NOTES & SPECIFICATIONS

In the interest of improved design, quality and performance, Mill-Max reserves the right to make changes in its specifications without prior notice. Specifications and tolerances are provided wherever possible. Due to the wide variety of interconnects Mill-Max offers, the specific tolerances vary from product to product. If you need information regarding the tolerance of a particular part, please contact Technical Services.

 © 2020 Mill-Max Mfg. Corp.
190 Pine Hollow Rd, Oyster Bay, NY 11771, USA
Phone: 516.922.6000